

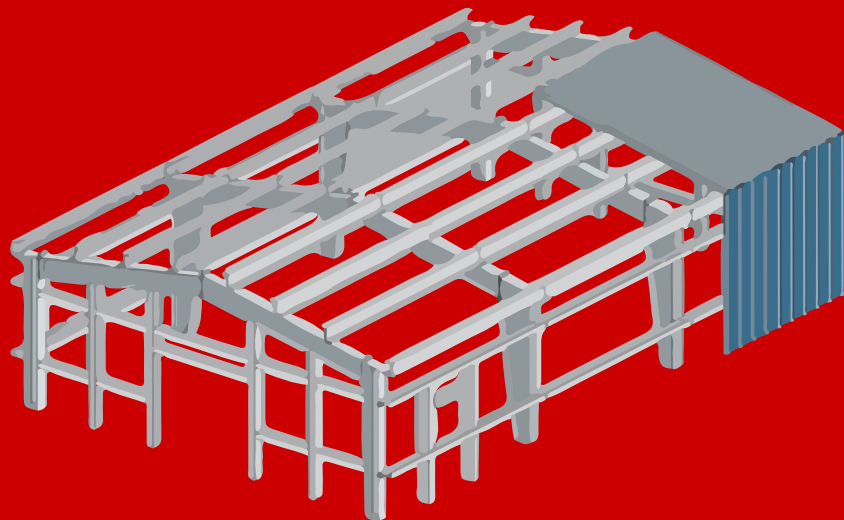

MANSEA METAL

METAL BUILDING
AND STANDING SEAM
COMPONENTS



COMMERCIAL AND INDUSTRIAL

KENTUCKY

925 Rolling Hills Ln.
Winchester, KY 40391
TEL: 859-744-4475
FAX: 859-744-4324



ILLINOIS

1181 S.R. 121
Mt. Zion, IL 62549
TEL: 217-864-5835
FAX: 217-864-2297

www.manseametal.com



COMMERCIAL BUILDING PANEL PROFILE SELECTIONS

PBR PANEL

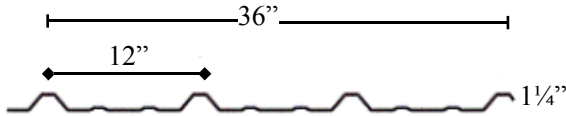

REVERSE PBR PANEL

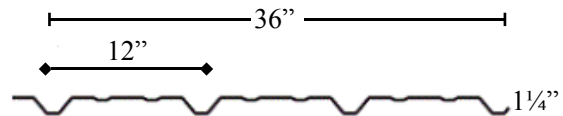

PANEL FINISH	GAUGE	MINIMUM THICKNESS	SUBSTRATE	COATING	WARRANTY	GRADE	WEIGHT (LFT)	PRICE
Clear Acrylic Resin	26	.0185	Galvalume®	AZ55	25	80	2.54#	\$3.87
SMP Standard Colors	26	.0185	Galvalume®	AZ50	40	80	2.54#	\$5.81

Pricing/Information Notes:

1. All Galvalume® panels are in conformance with ASTM A792 as per above specifications.
2. All Galvanized panels are in conformance with ASTM A653 as per above specifications.
3. The Clear Acrylic Resin on Galvalume® panels is a thin acrylic film intended to resist finger-printing and handling marks and to eliminate the use of lubricants in the roll-forming process. It is not a warranted film and could discolor during the weathering process.
4. Non-Warranted panels may contain shape and/or finish defects and are not rejectable or returnable for any reason. If higher quality is expected, please select a suitable warranted finish.
5. Length tolerance is 1/4" +/- of the ordered length.
6. Add a \$30.00 set-up charge for all reverse run panels.
7. Minimum panel length is 30".
8. Standard color selections are displayed on the current Mansea Metal Color Chart. For special colors, gauges or finishes, please inquire for pricing and availability.
9. Please inquire on large orders to verify available stock and delivery estimate.
10. All weights are estimates of actual material weights. Mansea Metal is not responsible for weight variances.
11. Edge of panels should never come in contact with concrete floor or sheeting notch. This will cause excessive edge creep and void the panel warranty.
12. Material should be inspected carefully prior to installation for any defects, including excessive oil-canning. Installation of material constitutes buyer acceptance.

ISOMETRIC VIEW

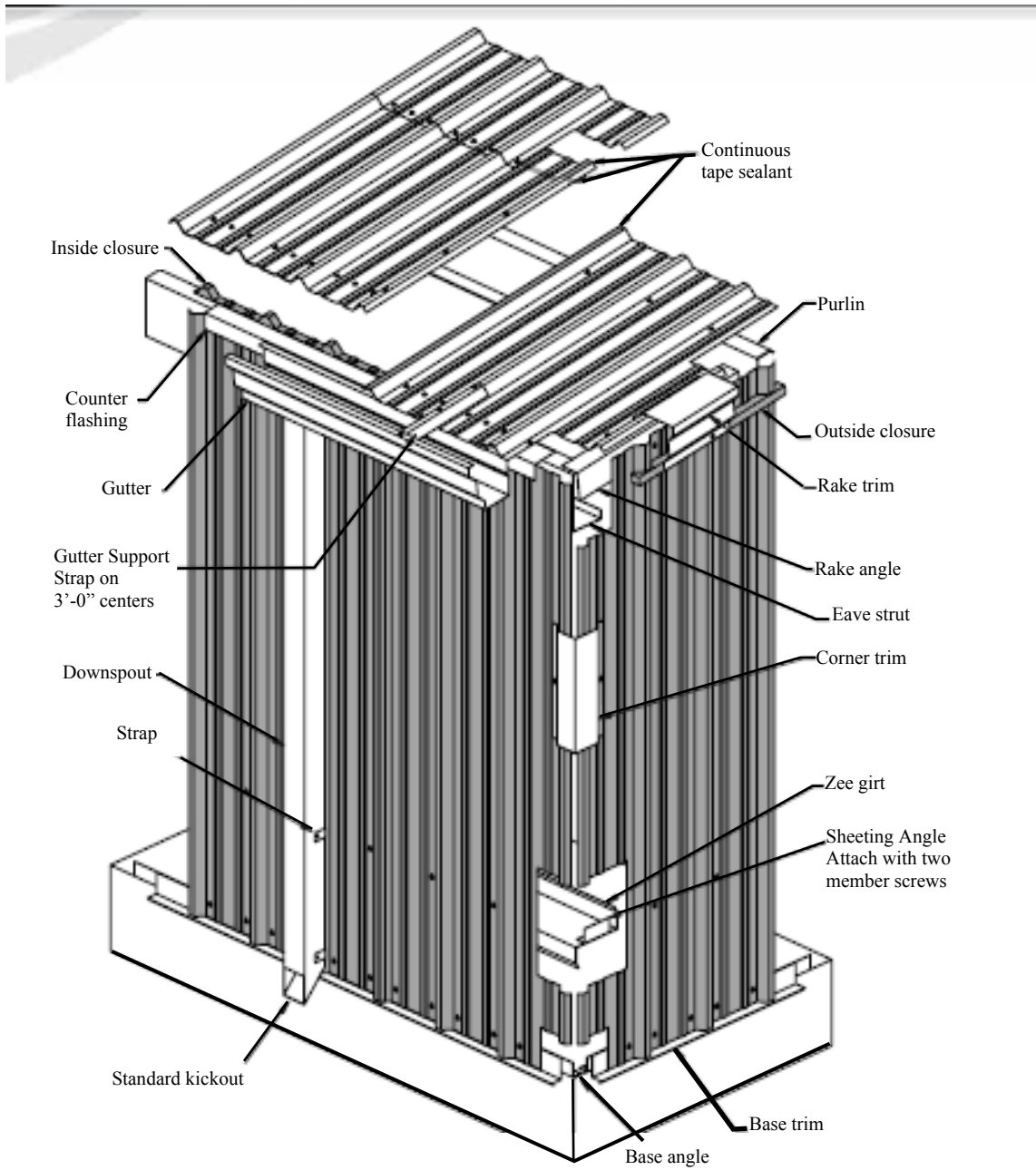

PBR TRIM

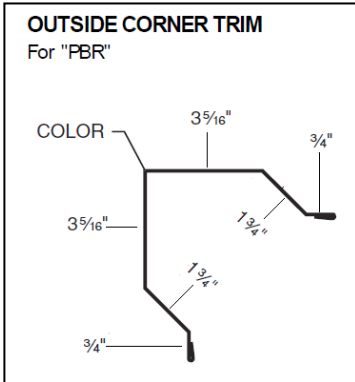

PRODUCT NO.	LENGTH	GIRTH	WEIGHT	PAINTED	GLUME
2603__	10' 2"	12 5/8"	8.32#	25.09	21.51
2603__12	12' 0"	12 5/8"	9.83#	30.03	25.73
2603__14	14' 0"	12 5/8"	11.46#	34.96	29.95
2603__16	16' 0"	12 5/8"	13.10#	39.90	34.18
2603__18	18' 0"	12 5/8"	14.74#	44.83	38.40
2603__20	20' 2"	12 5/8"	16.51#	49.76	42.64

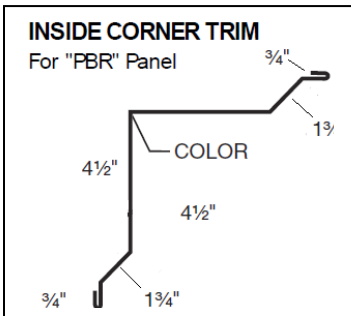

PRODUCT NO.	LENGTH	GIRTH	WEIGHT	PAINTED	GLUME
2604__	10' 2"	15"	9.89#	29.80	25.54
2604__12	12' 0"	15"	11.67#	35.66	30.57
2604__14	14' 0"	15"	13.62#	41.52	35.59
2604__16	16' 0"	15"	15.57#	47.38	40.61
2604__18	18' 0"	15"	17.51#	53.24	45.64
2604__20	20' 2"	15"	19.62#	59.10	50.66

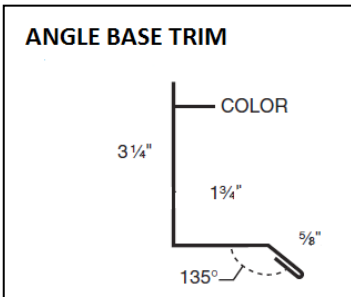

PRODUCT NO.	LENGTH	GIRTH	WEIGHT	PAINTED	GLUME
2608__	10' 2"	6 3/4"	4.45#	13.41	11.49

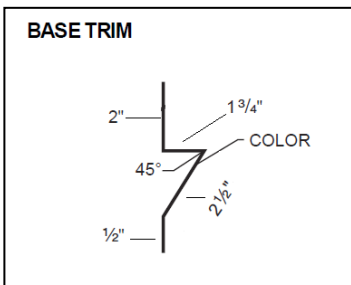

PRODUCT NO.	LENGTH	GIRTH	WEIGHT	PAINTED	GLUME
2618__	10' 2"	6 3/4"	4.45#	16.76	14.37

Dashes following product numbers are used to indicate the following color codes:

06 Black	80 Gallery Blue
70 Blue	00 Galvalume
73 Bright Red	25 Gray
12 Brown	63 Light Stone
49 Burnished Slate	30 Polar White
17 Charcoal	24 Red
26 Forest Green	22 Sahara Tan

**"PBR" SCULPTURED
EAVE GUTTER**

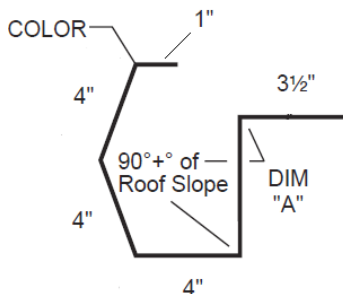

PRODUCT NO.	LENGTH	GIRTH	WEIGHT	PAINTED	GLUME
2654_ _	10' 2"	20 1/4"	15.17#	50.29	43.10
2654_ _20	20' 2"	20 1/4"	35.40#	99.74	85.49
*ROOF SLOPE	1/2 - 4:12				
*DIM "A"	6 1/2"				

**"PBR" SCULPTURED
HANG-ON GUTTER**

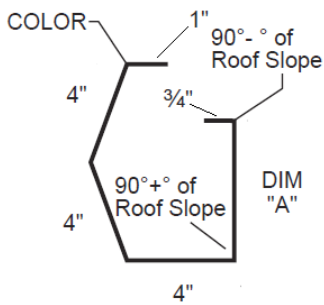

PRODUCT NO.	LENGTH	GIRTH	WEIGHT	PAINTED	GLUME
2655_ _	10' 2"	20 1/4"	14.50#	50.29	43.10
2655_ _20	20' 2"	20 1/4"	29.00#	99.74	85.49
*ROOF SLOPE	1/2 - 4:12				
*DIM "A"	6 1/2"				

GUTTER ENDS

Left or Right

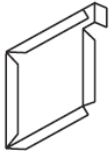

PRODUCT NO.	USE WITH ALL SCULPTURED GUTTERS	WEIGHT	PAINTED	GLUME
2694_ _	SPECIFY LEFT OR RIGHT	.39#	7.45	6.39

**BOX HANG-ON
GUTTER**

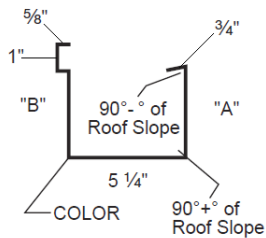

PRODUCT NO.	LENGTH	GIRTH	WEIGHT	PAINTED	GLUME
2657_ _	10' 2"	17"	11.21#	42.22	36.19
2657_ _20	20' 2"	17"	22.23#	83.73	71.77
*ROOF SLOPE	1/2 - 4:12				
*DIM "A"	4 1/2"				

Dashes following product numbers are used to indicate the following color codes:

06 Black	80 Gallery Blue
70 Blue	00 Galvalume
73 Bright Red	25 Gray
12 Brown	63 Light Stone
49 Burnished Slate	30 Polar White
17 Charcoal	24 Red
26 Forest Green	22 Sahara Tan

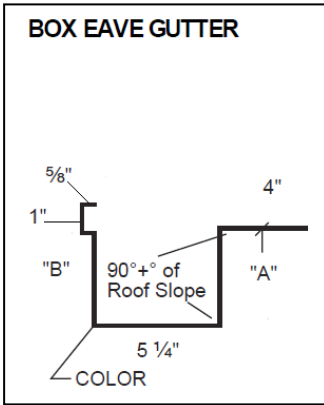

PRODUCT NO.	LENGTH	GIRTH	WEIGHT	PAINTED	GLUME
2656__	10' 2"	20 1/4"	13.35#	50.29	43.10
2656__20	20' 2"	20 1/4"	26.48#	115.74	99.21
*ROOF SLOPE	1/2 -4:12				
*DIM "A"	4 1/2"				

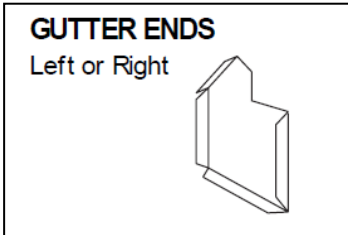

PRODUCT NO.	USE WITH ALL BOX GUTTER	WEIGHT	PAINTED	GLUME
2696__	SPECIFY LEFT OR RIGHT	.26#	7.45	6.39

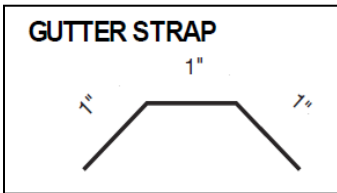

PRODUCT NO.	LENGTH	GIRTH	WEIGHT	PAINTED	GLUME
2691__	10' 2"	3"	.23#	5.96	5.11

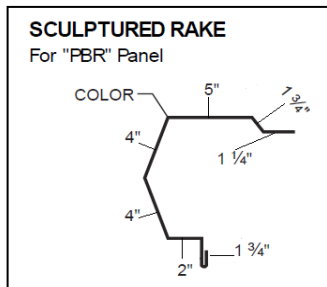

PRODUCT NO.	LENGTH	GIRTH	WEIGHT	PAINTED	GLUME
2652__	10' 2"	20 1/4"	14.50#	50.29	43.10
2652__20	20' 2"	20 1/4"	29.00#	99.74	85.49

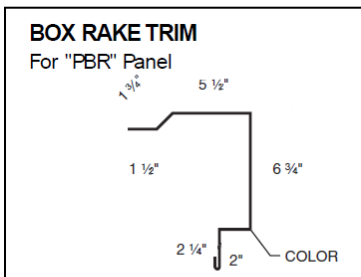

PRODUCT NO.	LENGTH	GIRTH	WEIGHT	PAINTED	GLUME
2653__	10' 2"	20 1/4"	13.35#	50.29	43.10
2653__20	20' 2"	20 1/4"	26.48#	99.74	85.49

Dashes following product numbers are used to indicate the following color codes:

- | | |
|--------------------|-----------------|
| 06 Black | 80 Gallery Blue |
| 70 Blue | 00 Galvalume |
| 73 Bright Red | 25 Gray |
| 12 Brown | 63 Light Stone |
| 49 Burnished Slate | 30 Polar White |
| 17 Charcoal | 24 Red |
| 26 Forest Green | 22 Sahara Tan |

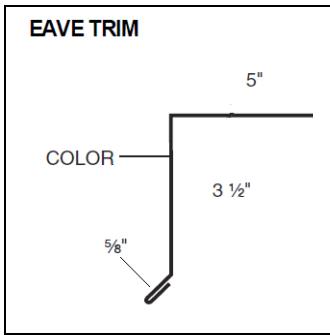

PRODUCT NO.	LENGTH	GIRTH	WEIGHT	PAINTED	GLUME
2647__	10' 2"	9 5/8"	6.35#	19.12	16.39
2647__20	20' 2"	9 5/8"	12.59#	37.92	32.51

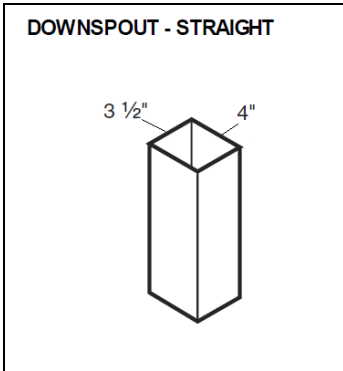

PRODUCT NO.	LENGTH	GIRTH	WEIGHT	PAINTED	GLUME
2683__	10' 2"	16 3/4"	11.04#	41.60	35.65
2683__12	12'	16 3/4"	13.05#	49.78	42.67
2683__14	14'	16 3/4"	15.21#	57.96	49.68
2683__16	16'	16 3/4"	17.38#	66.14	56.69
2683__20	20' 2"	16 3/4"	21.91#	82.50	70.71

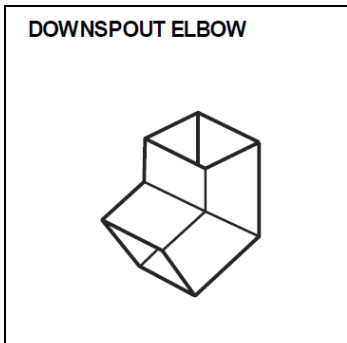

PRODUCT NO.	LENGTH	GIRTH	WEIGHT	PAINTED	GLUME
2680__	7"	16 3/4"	1.25#	18.87	16.18
*45° ELBOW					

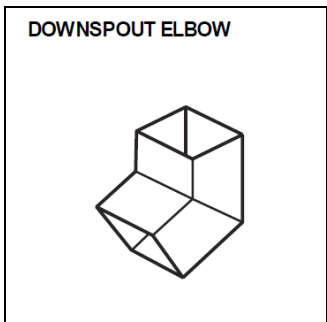

PRODUCT NO.	LENGTH	GIRTH	WEIGHT	PAINTED	GLUME
2681__	7"	16 3/4"	1.25#	18.87	16.18
*90° ELBOW					

Dashes following product numbers are used to indicate the following color codes:

06 Black	80 Gallery Blue
70 Blue	00 Galvalume
73 Bright Red	25 Gray
12 Brown	63 Light Stone
49 Burnished Slate	30 Polar White
17 Charcoal	24 Red
26 Forest Green	22 Sahara Tan

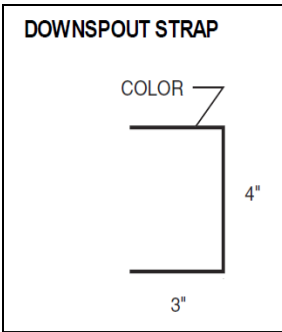

PRODUCT NO.	LENGTH	GIRTH	WEIGHT	PAINTED	GLUME
2690__	10' 2"	10"	.07#	5.96	5.11

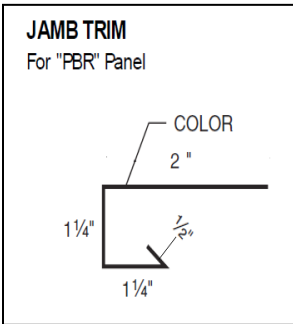

PRODUCT NO.	LENGTH	GIRTH	WEIGHT	PAINTED	GLUME
2609__	10' 2"	5"	2.35#	14.90	12.77
2609__14	14' 2"	5"	3.30#	20.76	17.79

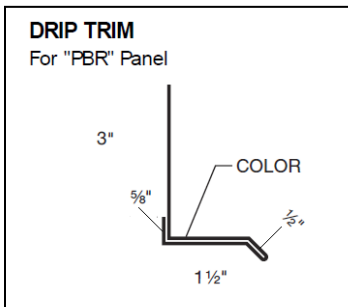

PRODUCT NO.	LENGTH	GIRTH	WEIGHT	PAINTED	GLUME
2621__	10' 2"	7 5/8"	5.03#	22.72	19.48

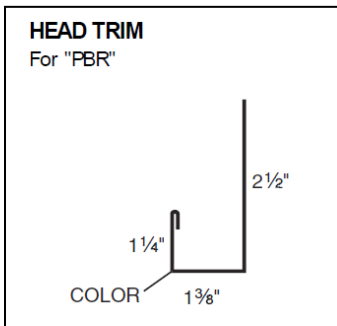

PRODUCT NO.	LENGTH	GIRTH	WEIGHT	PAINTED	GLUME
2610__	10' 2"	5 5/8"	3.62#	16.76	14.37
2610__14	14' 4"	5 5/8"	5.21#	23.36	20.02

Dashes following product numbers are used to indicate the following color codes:

06 Black	80 Gallery Blue
70 Blue	00 Galvalume
73 Bright Red	25 Gray
12 Brown	63 Light Stone
49 Burnished Slate	30 Polar White
17 Charcoal	24 Red
26 Forest Green	22 Sahara Tan



ENDWALL

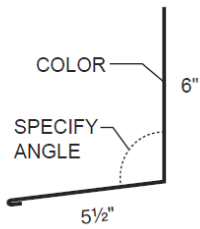

PRODUCT NO.	LENGTH	GIRTH	WEIGHT	PAINTED	GLUME
2648_ _	10' 2"	12"	7.91#	23.84	20.43

RAKEWALL

For "PBR" Panel

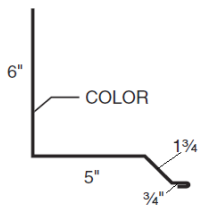

PRODUCT NO.	LENGTH	GIRTH	WEIGHT	PAINTED	GLUME
2650_ _	10' 2"	14"	9.23#	27.81	23.84
2650_ _20	20' 2"	14"	19.60#	55.16	47.28

2 x 2 INSIDE ANGLE

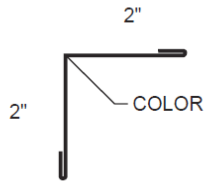

PRODUCT NO.	LENGTH	GIRTH	WEIGHT	PAINTED	GLUME
2611_ _	10' 2"	5"	3.30#	12.42	10.64

2 x 2 OUTSIDE ANGLE

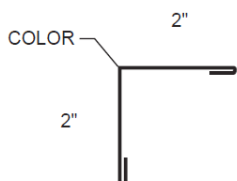

PRODUCT NO.	LENGTH	GIRTH	WEIGHT	PAINTED	GLUME
2612_ _	10' 2"	5"	3.30#	12.42	10.64

Dashes following product numbers are used to indicate the following color codes:

- | | |
|--------------------|-----------------|
| 06 Black | 80 Gallery Blue |
| 70 Blue | 00 Galvalume |
| 73 Bright Red | 25 Gray |
| 12 Brown | 63 Light Stone |
| 49 Burnished Slate | 30 Polar White |
| 17 Charcoal | 24 Red |
| 26 Forest Green | 22 Sahara Tan |

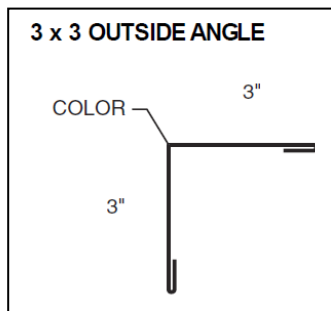

PRODUCT NO.	LENGTH	GIRTH	WEIGHT	PAINTED	GLUME
2614_ _	10' 2"	7"	4.70#	17.38	14.90

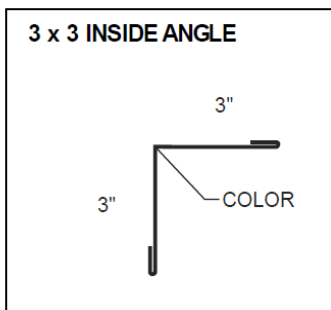

PRODUCT NO.	LENGTH	GIRTH	WEIGHT	PAINTED	GLUME
2613_ _	10' 2"	7"	4.70#	17.38	14.90

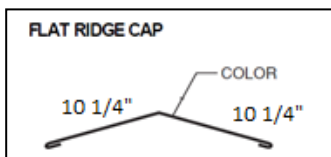

PRODUCT NO.	LENGTH	GIRTH	WEIGHT	PAINTED	GLUME
2602_ _	10' 2"	24"	15.82#	35.76	30.65
2602_ _20	20' 2"	24"	31.39#	82.74	70.92

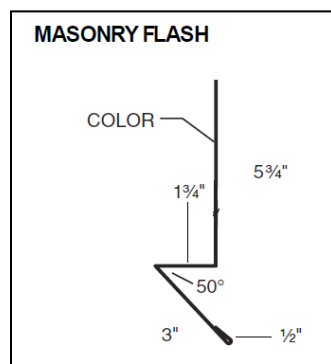

PRODUCT NO.	LENGTH	GIRTH	WEIGHT	PAINTED	GLUME
2619_ _	10' 2"	11"	7.70#	32.78	28.10
2619_ _20	20' 2"	11"	13.40#	65.01	55.73

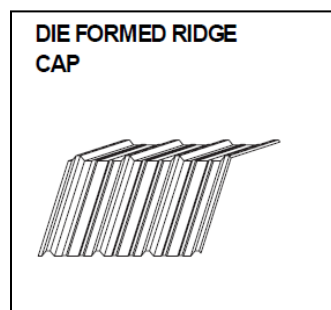

PRODUCT NO.	LENGTH	SLOPE	WEIGHT	PAINTED	GLUME
2670_ _	3'	1:12 to 4:12 p	8.55	37.80	30.00

Dashes following product numbers are used to indicate the following color codes:

- | | |
|--------------------|-----------------|
| 06 Black | 80 Gallery Blue |
| 70 Blue | 00 Galvalume |
| 73 Bright Red | 25 Gray |
| 12 Brown | 63 Light Stone |
| 49 Burnished Slate | 30 Polar White |
| 17 Charcoal | 24 Red |
| 26 Forest Green | 22 Sahara Tan |

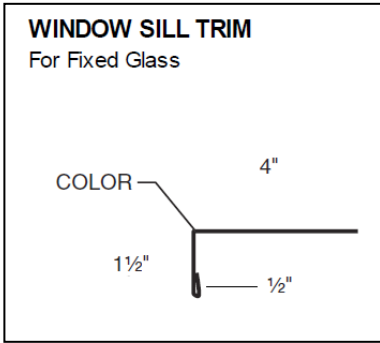

PRODUCT NO.	LENGTH	GIRTH	WEIGHT	PAINTED	GLUME
2615_ _	10' 2"	6"	3.96#	14.90	12.77

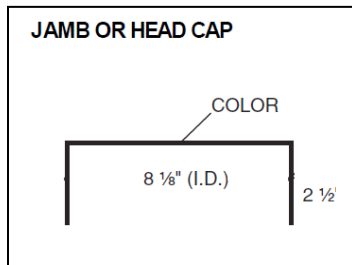

PRODUCT NO.	LENGTH	GIRTH	WEIGHT	PAINTED	GLUME
2620_ _	10' 2"	13 1/8"	8.65#	26.08	22.35

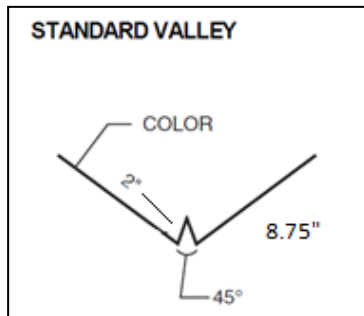

PRODUCT NO.	LENGTH	GIRTH	WEIGHT	PAINTED	GLUME
2651_ _	10' 2"	26"	17.80#	45.20	38.74
2651_ _20	20' 2"	26"	25.70#	89.64	76.83

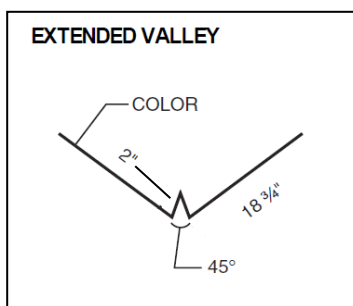

PRODUCT NO.	LENGTH	GIRTH	WEIGHT	PAINTED	GLUME
2649_ _	10' 2"	41 1/2"	27.85#	82.45	70.67
2649_ _20	20' 2"	41 1/2"	55.80#	163.52	140.16

Dashes following product numbers are used to indicate the following color codes:

- | | |
|--------------------|-----------------|
| 06 Black | 80 Gallery Blue |
| 70 Blue | 00 Galvalume |
| 73 Bright Red | 25 Gray |
| 12 Brown | 63 Light Stone |
| 49 Burnished Slate | 30 Polar White |
| 17 Charcoal | 24 Red |
| 26 Forest Green | 22 Sahara Tan |



RESIDENTIAL BUILDING PANEL PROFILE SELECTION

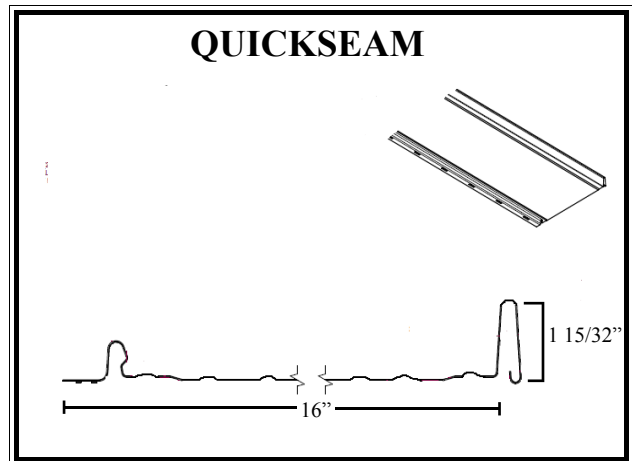
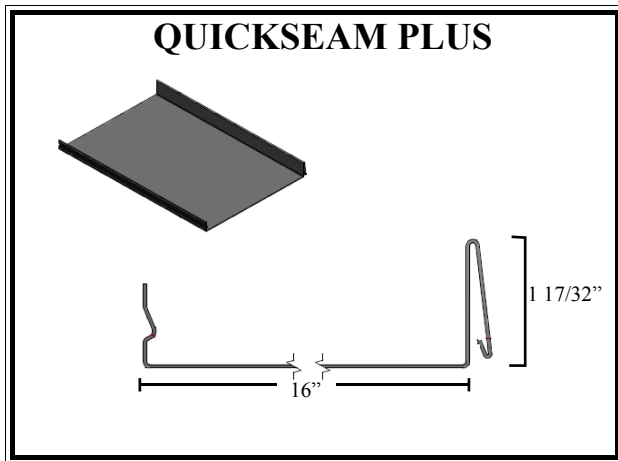

PANEL FINISH	GAUGE	MINIMUM THICKNESS	SUBSTRATE	COATING	WARRANTY	GRADE	WEIGHT (LFT)	PRICE
Clear Acrylic Resin	26	.0185	Galvalume®	AZ55	25	50	1.26#	\$3.33
SMP Standard Colors	26	.0185	Galvalume®	AZ50	40	50	1.26#	\$4.35

Pricing & Application Notes:

1. All Galvalume® panels are in conformance with ASTM A792 as per above specifications.
2. The Clear Acrylic Resin on Galvalume® panels is a thin acrylic film intended to resist fingerprinting and handling marks and to eliminate the use of lubricants in the roll-forming process. It is not a warranted film and could discolor during the weathering process.
3. Length tolerance is 1/4" +/- of the ordered length.
4. A minimum roof slope of 3:12 is required, installed over a flat 5/8" plywood deck.
5. "Oil-Canning" is not a cause for rejection.
6. Standard color selections are displayed on the current Mansea Metal color chart. For special colors, gauges, width, or finishes, please inquire for pricing and availability.
7. Please inquire on large orders to verify available stock and delivery estimate.
8. All weights are estimates of actual material weights. Mansea is not responsible for weight variances.
9. Material should be inspected carefully prior to installation for any defects, including excessive oil-canning. Installation of material constitutes buyer acceptance.
10. Standard panel is available with striations only.
11. 24 gauge panel is available in flat pan or with striations.

Packaging charges:

1. Price includes standard packaging and strippable film application.
2. Crating...\$100.00 (up to 15'-0) \$125.00 (15'-0 - 25'-0) \$150.00 (over 25'-0)

QUICKSEAM

QUICKSEAM TRIM

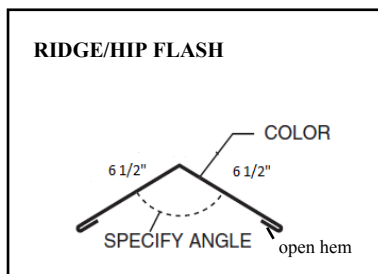

PRODUCT NO.	LENGTH	GIRTH	WEIGHT	GAUGE	PAINTED	GLUME
QS2602__	10' 2"	14"	6.40	26	27.81	20.86

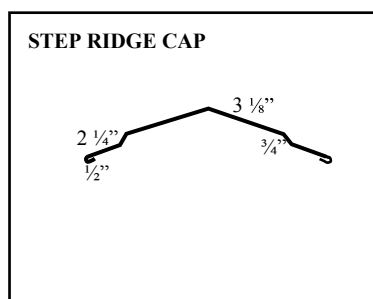

PRODUCT NO.	LENGTH	GIRTH	WEIGHT	GAUGE	PAINTED	GLUME
QS2601__	10' 2"	13 1/4"	6.25	26	33.77	28.95

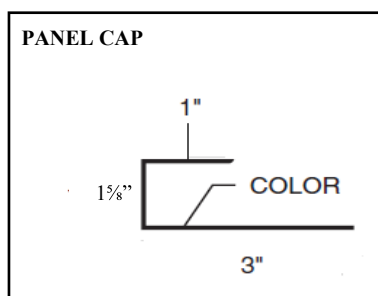

PRODUCT NO.	LENGTH	GIRTH	WEIGHT	GAUGE	PAINTED	GLUME
QS2609__	10' 2"	5 3/16"	2.89	26	13.04	11.18

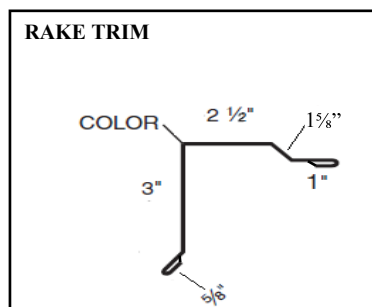

PRODUCT NO.	LENGTH	GIRTH	WEIGHT	GAUGE	PAINTED	GLUME
QS2604__	10' 2"	9"	5.60	26	20.12	17.24
QS2604__20	20' 2"	9"	11.21	26	39.89	34.20

Dashes following product numbers are used to indicate the following color codes:

06 BLACK	80 GALLERY BLUE
70 BLUE	00 GALVALUME
73 BRIGHT RED	25 GRAY
12 BROWN	63 LIGHT STONE
49 BURNISHED SLATE	15 PLUM
17 CHARCOAL	30 POLAR WHITE
26 FOREST GREEN	24 RED

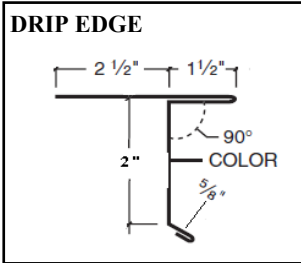

PRODUCT NO.	LENGTH	GIRTH	WEIGHT	GAUGE	PAINTED	GLUME
QS2648__	10' 2"	9"	5.89	26	22.35	19.16

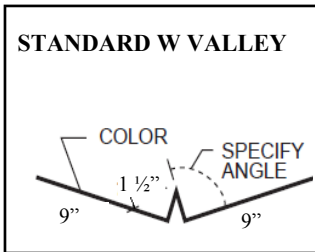

PRODUCT NO.	LENGTH	GIRTH	WEIGHT	GAUGE	PAINTED	GLUME
QS2651__	10' 2"	21 1/2"	10.80	26	37.37	32.04

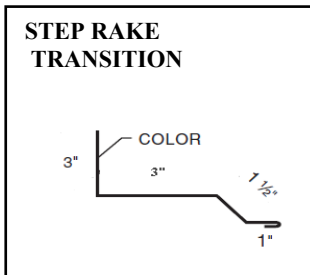

PRODUCT NO.	LENGTH	GIRTH	WEIGHT	GAUGE	PAINTED	GLUME
QS2650__	10' 2"	10"	6.30	26	24.83	21.29
QS2650__20	20' 2"	10"	12.60	26	49.25	42.22

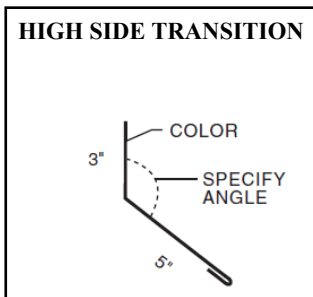

PRODUCT NO.	LENGTH	GIRTH	WEIGHT	GAUGE	PAINTED	GLUME
QS2620__	10' 2"	8 1/2"	5.60	26	21.11	18.09

Dashes following product numbers are used to indicate the following color codes:

- | | |
|--------------------|-----------------|
| 06 BLACK | 80 GALLERY BLUE |
| 70 BLUE | 00 GALVALUME |
| 73 BRIGHT RED | 25 GRAY |
| 12 BROWN | 63 LIGHT STONE |
| 49 BURNISHED SLATE | 15 PLUM |
| 17 CHARCOAL | 30 POLAR WHITE |
| 26 FOREST GREEN | 24 RED |



PEAK CAP

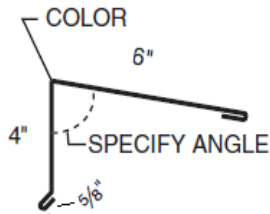

PRODUCT NO.	LENGTH	GIRTH	WEIGHT	GAUGE	PAINTED	GLUME
QS2657__	10' 2"	11 5/8"	7.42	26	28.87	24.76

FASCIA ANGLE

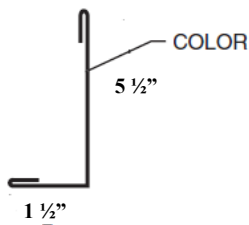

PRODUCT NO.	LENGTH	GIRTH	WEIGHT	GAUGE	PAINTED	GLUME
QS2611__	10' 2"	8"	5.10	26	19.87	17.03

F-CHANNEL

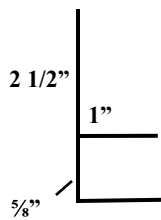

PRODUCT NO.	LENGTH	GIRTH	WEIGHT	GAUGE	PAINTED	GLUME
QS2661__	10' 2"	6 3/4"	3.99	26	20.12	17.24

EAVE TRIM

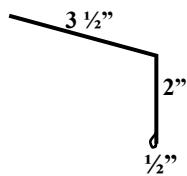

PRODUCT NO.	LENGTH	GIRTH	WEIGHT	GAUGE	PAINTED	GLUME
QS2647__	10' 2"	6"	3.23	26	17.88	15.33

Dashes following product numbers are used to indicate the following color codes:

- | | |
|--------------------|-----------------|
| 06 BLACK | 80 GALLERY BLUE |
| 70 BLUE | 00 GALVALUME |
| 73 BRIGHT RED | 25 GRAY |
| 12 BROWN | 63 LIGHT STONE |
| 49 BURNISHED SLATE | 15 PLUM |
| 17 CHARCOAL | 30 POLAR WHITE |
| 26 FOREST GREEN | 24 RED |

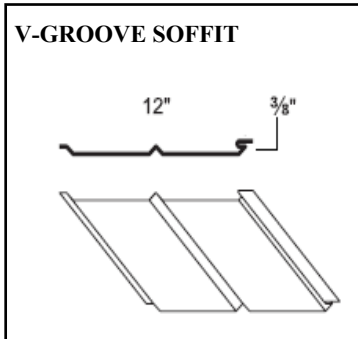

PRODUCT NO.	LENGTH	GIRTH	WEIGHT	GAUGE	PAINTED	GLUME
SOF26__S	10' 2"	14"	8.80	26	41.72	35.76

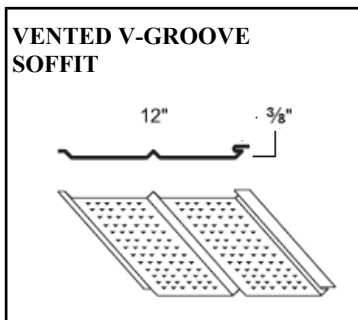

PRODUCT NO.	LENGTH	GIRTH	WEIGHT	GAUGE	PAINTED	GLUME
SOF26__V	10' 2"	14"	8.80	26	41.72	35.76



PRODUCT NO.	LENGTH	GIRTH	WEIGHT	GAUGE	PAINTED	GLUME
2600__	10' 2"	43"	25.43	26	53.39	45.77

Dashes following product numbers are used to indicate the following color codes:

06 BLACK	80 GALLERY BLUE
70 BLUE	00 GALVALUME
73 BRIGHT RED	25 GRAY
12 BROWN	63 LIGHT STONE
49 BURNISHED SLATE	15 PLUM
17 CHARCOAL	30 POLAR WHITE
26 FOREST GREEN	24 RED

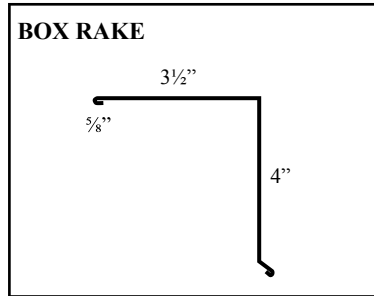

PRODUCT NO.	LENGTH	GIRTH	WEIGHT	GAUGE	PAINTED	GLUME
QS2603__	10' 2"	8 3/4"	4.99	26	21.73	18.63
QS2603__20	20' 2"	8 3/4"	9.99	26	43.10	37.99

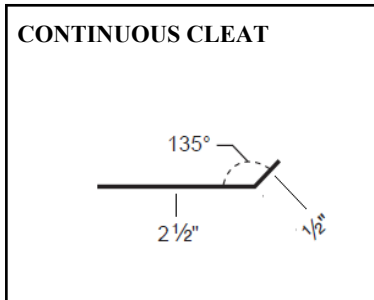

PRODUCT NO.	LENGTH	GIRTH	WEIGHT	GAUGE	PAINTED	GLUME
QS2690__	10' 2"	3"	1.98	26	7.45	6.39

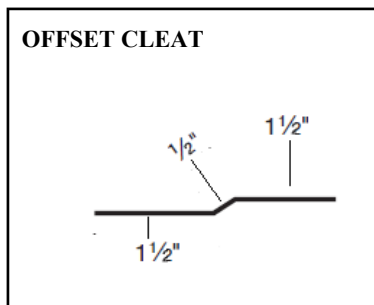

PRODUCT NO.	LENGTH	GIRTH	WEIGHT	GAUGE	PAINTED	GLUME
QS2691__	10' 2"	3 1/2"	2.00	26	8.69	7.45

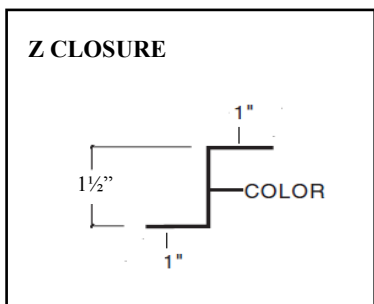

PRODUCT NO.	LENGTH	GIRTH	WEIGHT	GAUGE	PAINTED	GLUME
QS2615__	10' 2"	3 5/8"	2.15	26	9.73	8.34

Dashes following product numbers are used to indicate the following color codes:

06 BLACK	80 GALLERY BLUE
70 BLUE	00 GALVALUME
73 BRIGHT RED	25 GRAY
12 BROWN	63 LIGHT STONE
49 BURNISHED SLATE	15 PLUM
17 CHARCOAL	30 POLAR WHITE
26 FOREST GREEN	24 RED

QUICKSEAM PLUS

QUICKSEAM PLUS TRIM

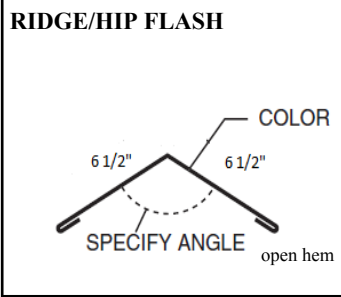

PRODUCT NO.	LENGTH	GIRTH	WEIGHT	GAUGE	PAINTED	GLUME
QSP2602__	10' 2"	13"	6.40	26	27.81	20.86

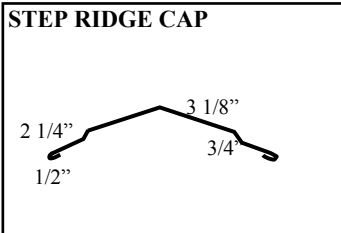

PRODUCT NO.	LENGTH	GIRTH	WEIGHT	GAUGE	PAINTED	GLUME
QSP2601__	10' 2"	13 1/4"	6.25	26	33.77	28.95

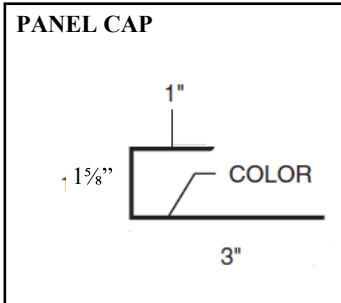

PRODUCT NO.	LENGTH	GIRTH	WEIGHT	GAUGE	PAINTED	GLUME
QSP2609__	10' 2"	5 5/8"	2.89	26	13.04	11.18

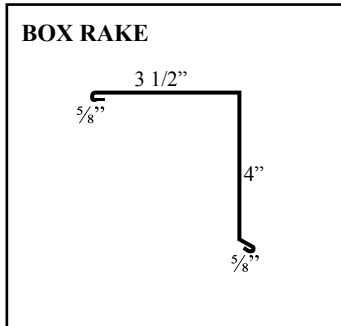

PRODUCT NO.	LENGTH	GIRTH	WEIGHT	GAUGE	PAINTED	GLUME
QSP2603__	10' 2"	8 3/4"	4.99	26	21.73	18.63
QSP2603__20	20' 2"	8 3/4"	9.99	26	43.10	37.99

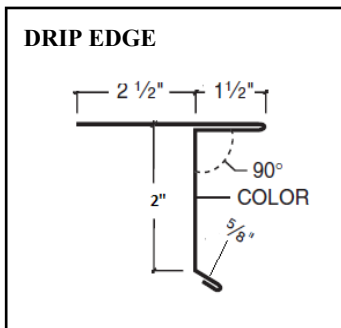

PRODUCT NO.	LENGTH	GIRTH	WEIGHT	GAUGE	PAINTED	GLUME
QSP2648__	10' 2"	8 5/8"	5.89	26	22.35	19.16

Dashes following product numbers are used to indicate the following color codes:

06 BLACK	80 GALLERY BLUE
70 BLUE	00 GALVALUME
73 BRIGHT RED	25 GRAY
12 BROWN	63 LIGHT STONE
49 BURNISHED SLATE	15 PLUM
17 CHARCOAL	30 POLAR WHITE
26 FOREST GREEN	24 RED

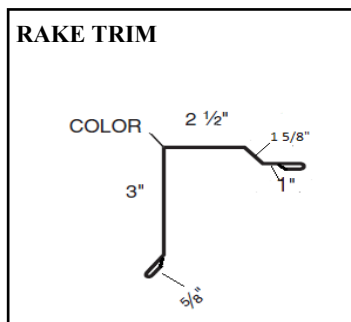

PRODUCT NO.	LENGTH	GIRTH	WEIGHT	GAUGE	PAINTED	GLUME
QSP2604__	10' 2"	9"	5.60	26	24.83	17.24
QSP2604__20	20' 2"	9"	11.21	26	49.25	34.20

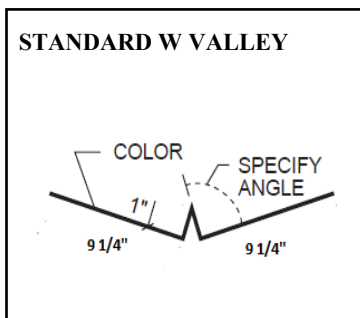

PRODUCT NO.	LENGTH	GIRTH	WEIGHT	GAUGE	PAINTED	GLUME
QSP2651__	10' 2"	21 1/2"	10.80	26	37.37	32.04

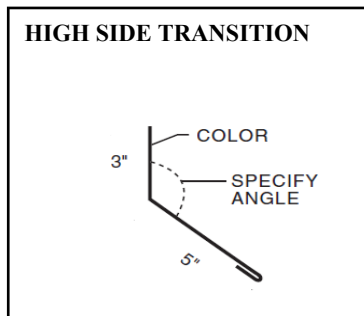

PRODUCT NO.	LENGTH	GIRTH	WEIGHT	GAUGE	PAINTED	GLUME
QSP2620__	10' 2"	8 1/2"	5.60	26	21.11	18.09

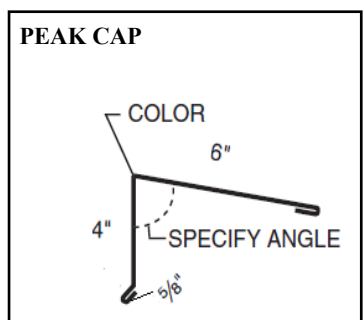

PRODUCT NO.	LENGTH	GIRTH	WEIGHT	GAUGE	PAINTED	GLUME
QSP2657__	10' 2"	11 5/8"	7.42	26	28.87	24.76

Dashes following product numbers are used to indicate the following color codes:

06 BLACK	80 GALLERY BLUE
70 BLUE	00 GALVALUME
73 BRIGHT RED	25 GRAY
12 BROWN	63 LIGHT STONE
49 BURNISHED SLATE	15 PLUM
17 CHARCOAL	30 POLAR WHITE
26 FOREST GREEN	24 RED



RAKE TRANSITION

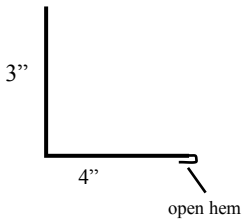

PRODUCT NO.	LENGTH	GIRTH	WEIGHT	GAUGE	PAINTED	GLUME
QSP2650__	10' 2"	7 1/2"	6.30	26	18.63	15.96

CONTINUOUS CLEAT

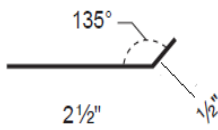

PRODUCT NO.	LENGTH	GIRTH	WEIGHT	GAUGE	PAINTED	GLUME
QSP2690__	10' 2"	3"	1.98	26	7.45	6.39

OFFSET CLEAT

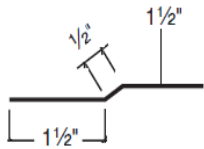

PRODUCT NO.	LENGTH	GIRTH	WEIGHT	GAUGE	PAINTED	GLUME
QSP2691__	10' 2"	3 1/2"	2.00	26	8.69	7.45

Z CLOSURE

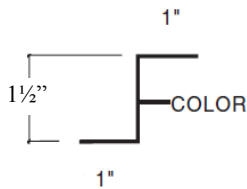

PRODUCT NO.	LENGTH	GIRTH	WEIGHT	GAUGE	PAINTED	GLUME
QSP2615__	10' 2"	3 5/8"	2.15	26	9.73	8.34

FASCIA ANGLE

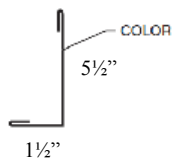

PRODUCT NO.	LENGTH	GIRTH	WEIGHT	GAUGE	PAINTED	GLUME
QSP2611__	10' 2"	8"	5.10	26	19.87	17.03

Dashes following product numbers are used to indicate the following color codes:

06 BLACK	80 GALLERY BLUE
70 BLUE	00 GALVALUME
73 BRIGHT RED	25 GRAY
12 BROWN	63 LIGHT STONE
49 BURNISHED SLATE	15 PLUM
17 CHARCOAL	30 POLAR WHITE
26 FOREST GREEN	24 RED

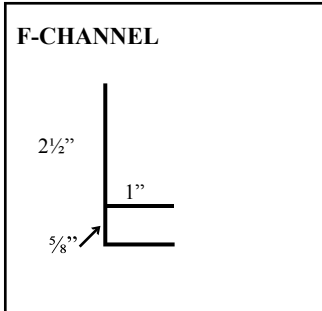

PRODUCT NO.	LENGTH	GIRTH	WEIGHT	PAINTED	GLUME
QSP2661__	10' 2"	6 3/4"	3.99	20.12	17.24

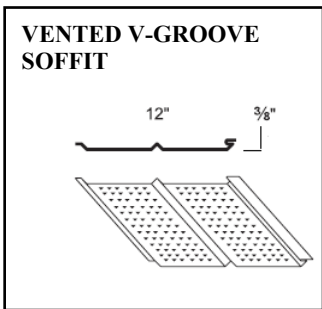

PRODUCT NO.	LENGTH	GIRTH	WEIGHT	GAUGE	PAINTED	GLUME
SOF26__V	10' 2"	13 3/4"	8.80	26	41.72	35.76

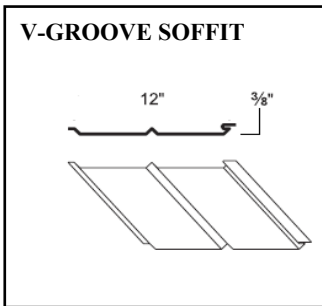

PRODUCT NO.	LENGTH	GIRTH	WEIGHT	GAUGE	PAINTED	GLUME
SOF26__S	10' 2"	13 3/4"	8.80	26	41.72	35.76



PRODUCT NO.	LENGTH	GIRTH	WEIGHT	GAUGE	PAINTED	GLUME
2600__	10' 2"	43"	3.00	26	53.39	45.77

Dashes following product numbers are used to indicate the following color codes:

06 BLACK	80 GALLERY BLUE
70 BLUE	00 GALVALUME
73 BRIGHT RED	25 GRAY
12 BROWN	63 LIGHT STONE
49 BURNISHED SLATE	15 PLUM
17 CHARCOAL	30 POLAR WHITE
26 FOREST GREEN	24 RED

PBR AND QUICKSEAM ACCESSORIES

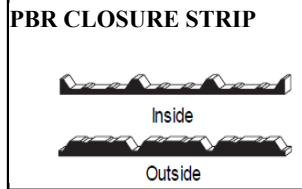

PART NO.	TYPE	ADHESIVE	SIZE	CARTON SIZE	WEIGHT	PRICE
A110	INSIDE	YES	1"	100	.04#	
A111	OUTSIDE	YES	1"	100	.08#	



PART NO.	TYPE	ADHESIVE	SIZE	CARTON SIZE	WEIGHT	PRICE
A105B	OUTSIDE	YES	1"	25	.09#	

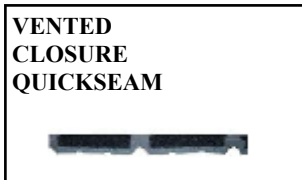

PART NO.	TYPE	ADHESIVE	SIZE	CARTON SIZE	WEIGHT	PRICE
A103	OUTSIDE	YES	1 1/2"	25	.08#	



PART NO.	ADHESIVE	SIZE	CARTON SIZE	WEIGHT	LENGTH	PRICE
A106	YES	1" (EXPANDED)	26	1.25#	19' 6"	

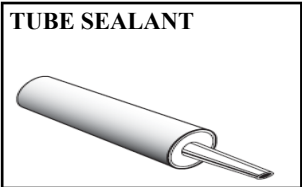

PART NO.	TYPE	COLOR	TUBE SIZE	CARTON SIZE	PRICE
A12__	SOLAR SEAL	ALL	10.3 FL. OZ.	12	

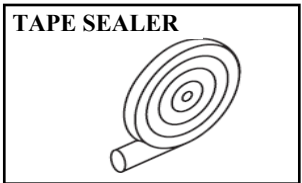

PART NO.	TYPE	WIDTH	THICKNESS	LENGTH	CARTON QTY	ROLL WEIGHT	PRICE
A107	FLAT	3/8"	3/32"	45'	48	1.20#	
A108	FLAT	3/4"	3/32"	50'	10	2.65#	



PART NO.	TEMPERATURE RANGE	PIPE SIZE	PRICE
A201E	-58° F TO +239°F	1/4" - 5 3/4"	



PART NO.	TEMPERATURE RANGE	PIPE SIZE	PRICE
A201	-58°F TO +239°F	3/4" - 2 1/2"	
A202	-58°F TO +239°F	2" - 7 1/4"	

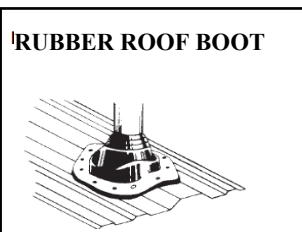

PART NO.	ROOF BOOT	TEMPERATURE RANGE	PIPE SIZE	PRICE
A203	#3	-58° F TO +239°F	1/4" - 5"	
A205	#6	-58°F TO +239°F	5" - 9"	
A208	#8	-58° TO +239°F	7" - 13"	
A209	#9	-58° TO +239°F	10" - 18"	

**RUBBER ROOF BOOT
HIGH TEMPERATURE**

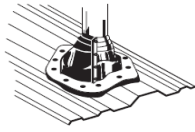

PART NO.	ROOF BOOT	TEMPERATURE RANGE	PIPE SIZE	PRICE
A204	#3	-58°F TO +392°F	1/4" - 5"	
A206	#6	-58°F TO +392°F	5" - 9"	
207	#8	-58°F TO +392°F	7" - 13"	
209H	#9	-58° TO +392°F	10" - 18"	

DEKSTRIP

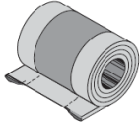

PART NO.	TEMPERATURE RANGE	SIZE	LF PRICE
A109	-58°F TO +239°F	18" X 50'	

**LIGHT TRANSMITTING
PANEL**

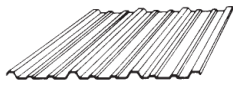

PART NO.	LENGTH	COLOR	SQ. FT WEIGHT	WEIGHT EACH	PRICE
S210	10'	WHITE	8 OZ.	16.50#	
S212	12'	WHITE	8 OZ.	17.20#	
S216	16'	WHITE	8 OZ.	18.50#	

**SINGLE BUBBLE
DOUBLE BUBBLE
INSULATION**

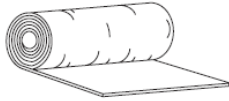

PART NO.	WIDTH	LENGTH	SQ FT ROLL	WEIGHT	PRICE
A4125	4'	125'	500	14#	
A6125	6'	125'	750	21#	
DB4125	4'	125'	500	22#	
DB6125	6'	125'	750	31#	

**DOUBLE FACED
TAPE**



PART NO.	WIDTH	LENGTH	WEIGHT PER ROLL	PRICE
FG1001	1 1/2"	180'	1#	

**ALUMINUM FOIL
TAPE**



PART NO.	WIDTH	LENGTH	WEIGHT PER ROLL	PRICE
FG1003	3"	150'	1#	

**SHURTAPE
LAP TAPE**



PART NO.	WIDTH	LENGTH	WEIGHT PER ROLL	PRICE
FG1002	3"	150'	1#	

FIBERGLASS INSULATION

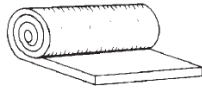

PART NO.	DESCRIPTION	PRICE
FG304100	3" VRR PLUS 4'X100' FG INS (R10)	
FG306100	3" VRR PLUS 6'X100' FG INS (R10)	
FG404100	4" VRR PLUS 4'X100' FG INS (R13)	
FG406100	4" VRR PLUS 6'X100' FG INS (R13)	
FG604100	6" VRR PLUS 4'X100' FG INS (R19)	
FG606100	6" VRR PLUS 6'X100' FG INS (R19)	

FIXED CLIP

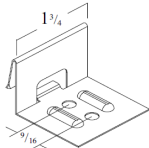

PART NO.	SSR SYSTEM	HEIGHT	WEIGHT EACH	PRICE
Q5450	QUICKSEAM PLUS	1 1/4"	.9 OZ	

WOOD FASTENER



PART NO.	LENGTH	HEAD SIZE	TYPE	BAG QTY	WEIGHT PER BAG	PLATED	PAINTED
101__	1"	1/4"	WOOD FASTENER	250	2.2#		
115__	1 1/2"	1/4"	WOOD FASTENER	250	2.8#		
102__	2"	1/4"	WOOD FASTENER	250	3.3#		
125__	2 1/2"	1/4"	WOOD FASTENER	250	3.85#		

1" PANCAKE HEAD WOODSCREW



PART NO.	HEAD SIZE	TYPE	BAG QUANTITY	WEIGHT PER BAG	PRICE
SS101	#2	A	250	1.85#	

1/8" X 3/16" POP RIVET



PART NO.	TYPE	BAG QUANTITY	WEIGHT PER BAG	PRICE
18316__	STAINLESS STEEL	250	.725#	

1 1/4" SELF DRILLER

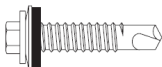

PART NO.	HEAD SIZE	TYPE	BAG QUANTITY	WEIGHT PER BAG	PLATED	PAINTED
SD114__	5/16"	DRILLER	250	4.4#		

7/8" LapTEK

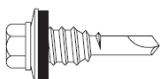

PART NO.	HEAD SIZE	TYPE	BAG QUANTITY	WEIGHT PER BAG	PLATED	PAINTED
178__	5/16"	LapTEK	250			



PART NO.	TYPE	COLOR	PRICE
TPO__	BRUSH	SEE COLOR CHART	



PART NO.	TYPE	COLOR	PRICE
TPO__	SPRAY	SEE COLOR CHART	



PART NO.	SQ FT	SIZE	PRICE
210	1000	4' X 250'	



PART NO.	SQ FT	SIZE	PRICE
230	200	36" x 72"	



925 Rolling Hills Lane
Winchester, KY 40391

Phone: 859-744-4475
Fax: 859-744-4324

1181 S.R. 121
Mt. Zion, IL 62549

Phone: 217-864-5835
Fax: 217-864-2297



No

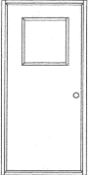

22x22 V

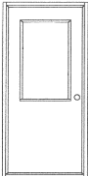

22x36 O

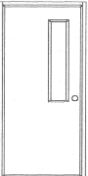

8x36 NL

Part Number	Size	Lite	Color	Weight Each	Price
51015	3070	No	White	98	\$1,366.01
51154	3070	V	White	103	\$1,330.90
51364	3070	O	White	108	\$1,340.14
	3070	NL	White	103	\$1,369.09
51186	4070	No	White	110	\$1,261.46
51190	4070	V	White	115	\$1,543.81
51365	4070	O	White	121	\$1,553.08
	4070	NL	White	115	\$1,582.04
51019	6070	No	White	206	\$2,298.38
51204	6070	V	White	216	\$2,861.98
	6070	O	White	226	\$2,880.49
	6070	NL	White	216	\$2,695.16

Note:

- * 24 ga panel, pre-hung in a 16 ga steel frame with three 4.5"x4" fixed pin stainless steel hinges
- * 6070 door includes astragal installed on the inactive panel
- * Door leaf is pre-drilled for entry lockset
- * ADA, low profile sill

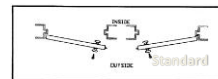
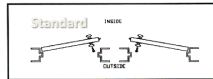

Part Number	Description	Price
3853S	Stainless Steel Ball Bearing Hinge	\$37.71
6742	TACO - Door closer - series 70	\$257.54
5220	Touch bar exit w/ exterior lever	\$605.25
6665	Vertical rod. 6070	\$608.54
1448	Schlage Saturn Lever/Lever lockset	\$556.07
3912	Tell Courtland Lever/Lever lockset	\$252.59
50999	16 ga Steel Sub Frame Kit	\$387.09
4579	Prep charge for keying locksets	\$32.81

Part Number	Size	Style	Color	Weight Each	Price
90020J	3020	Slider	White	28	\$438.63
90035J	4030	Slider	White	48	\$650.40
90056H	6040	Slider	White	108	\$999.90
90502J	3020	Fixed	White	32	\$374.97
90508J	4030	Fixed	White	65	\$518.48
90517J	6040	Fixed	White	146	\$1,170.02



Slider



Fixed

Fire Rated Doors available: 45 min, 90 min & 3 hour --- call for pricing

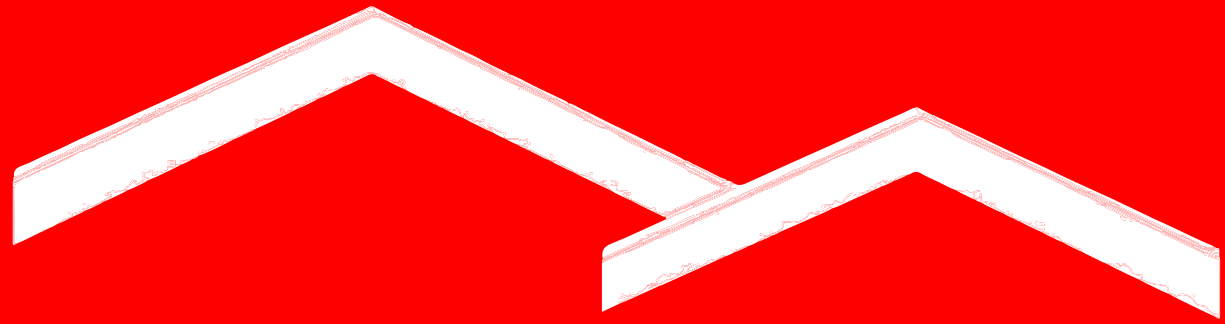

MANSEA METAL

We ARE the manufacturer!

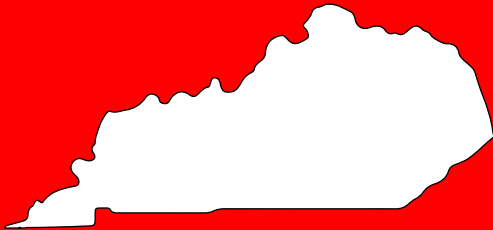

KENTUCKY

(corporate)

925 Rolling Hills Ln.
Winchester, KY 40391

TEL: 859-744-4475
FAX: 859-744-4324

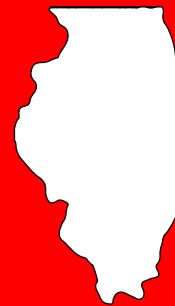

ILLINOIS

1181 S.R. 121
Mt. Zion, IL 62549

TEL: 217-864-5835
FAX: 217-864-2297

www.manseametal.com